

Rohs

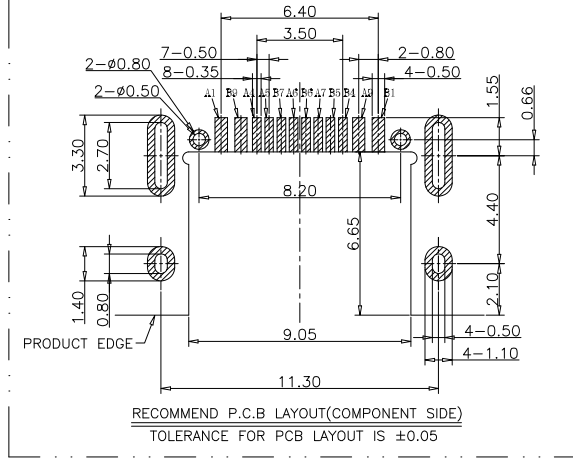

REV.	DESCRIPTION	DRAW.	DATE.

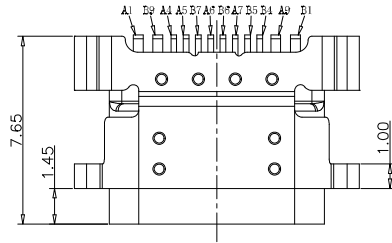

- 备注(NOTE):
- 电气特性:
 - 接触区: 接触电阻40mΩ Max, 允许10mΩ变化量 测试条件: 20mv, 100mA下测量
 - 接触电流: 3A VBUS引脚; 1.25A用于GND引脚; 其他引脚为0.25A.
 - 额定电压: 30V.
 - 耐电压: 100VR.M.S.
 - 绝缘电阻: 至少100兆欧
 - 机械性能:
 - 插入力: 0.51-2.04Kg
 - 拔出力: 0.82-2.04Kg
 - 耐久性: 0.61-2.04Kg
 - 插拔次数: 10000次
 - 工作环境: -20℃ to +85℃.

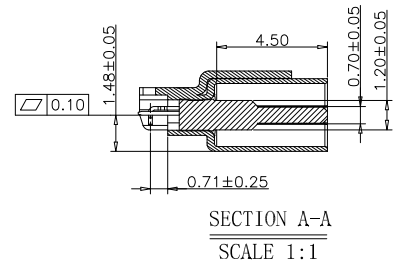
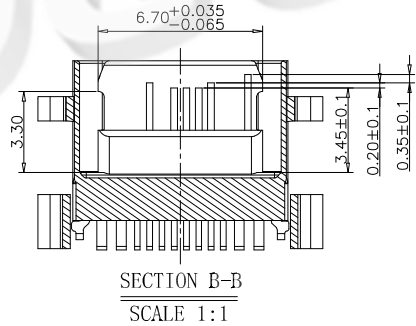
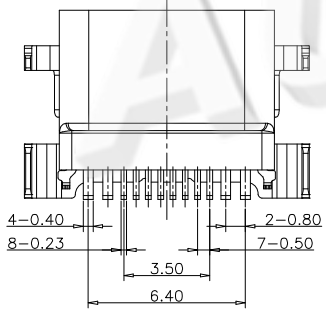
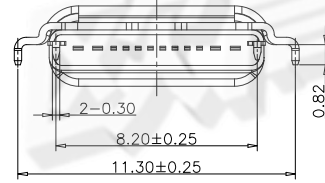
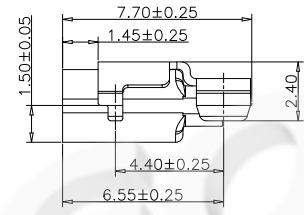
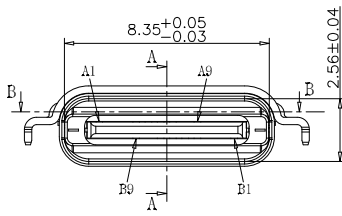

USB TYPE C PIN ASSIGNMENTS

PIN NUMBER	SIGNAL NAME	PIN NUMBER	SIGNAL NAME
A1	GND		
A4	VBUS	B9	VBUS
A5	CC1		
A6	Dp1	B7	Dn2
A7	Dn1	B6	Dp2
		B5	CC2
A9	VBUS	B4	VBUS
		B1	GND

TABLE:

NO	PART	Q'TY	Material
1	SHELL-1	1	STAINLESS STEEL,Ni PLATED 30u"Min
2	SHELL-2	1	STAINLESS STEEL,Ni PLATED 30u"Min
3	CONTACT	12	COPPER STEEL,Ni 50u"Min;Au u"
4	MID PLATE	1	STAINLESS STEEL,NO PLATING
5	MD HOUSING	1	HIGH TEMPERATURE RESISTANT PLASTIC BLACK UL94 V-0

AUGO

AUGO ELECTRONICS CO.,LTD.

REV:	01	UNLESS OTHERWISE SPECIFIED,TOLERANCE: X. ±0.20 X.x ±0.15 X.xx ±0.10 ANGULAR ±2°
SIZE:	A4	
SCALE:1:1	UNIT:mm	
SHEET:1/1		

TITLE:	TYPE-C SERIES	DESIGN	H.Y.ZHU	DATE	
PART NO:	TYPE C 12P 防水母座 拉伸壳四脚护套L=7.65MM	DRAWING	W.B.QIAO	DATE	
		CHECK	G.C.CHEN	DATE	
		SCALE	1:1	PAGE	1 OF 1

COPYRIGHT RESERVED,PLEASE DO NOT COPY.