

CAD FILE:

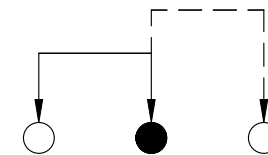

SCHEMATIC (NON-SHORTING)

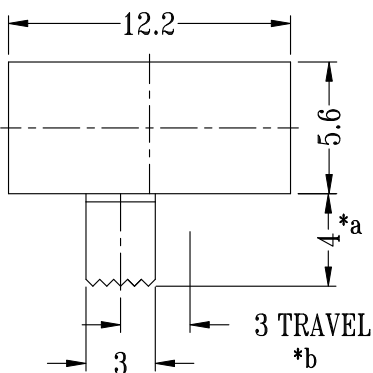
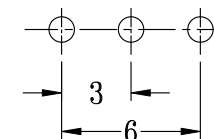
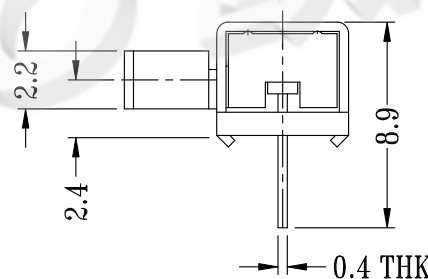
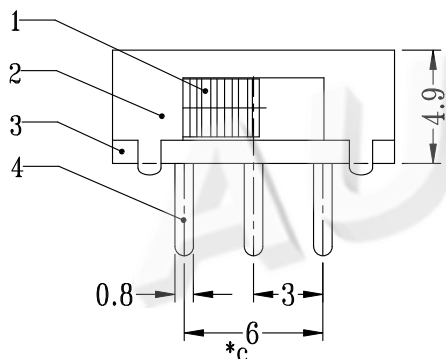

P.C.B LAYOUT  
BOTTOM VIEW

注：“\*”表示关键尺寸（3）

NO.	PART NAME	MATERIAL	Q'TY	FINISHING	TOLERANCE UNLESS SPECIFIED	ISSUE	DATE	DESCRIPTIONS OF REVISION	APPD.
8									
7									
6	SPRING	STEEL WIRE	1	NATURAL	WITHIN 1.5mm : ±0.1mm	A	2012-8-14	初版	
5	CONTACT	BRASS STRIP	1	Ag PLATED	OVER 1.5mm : ±0.2mm				
4	TERMINAL	BRASS STRIP	3	Ag PLATED					
3	BASE	PHENOLIC RESIN	1	NATURAL	TITLE : HORIZONTAL SLIDE SWITCH			UNIT : mm	DRWG NO.: AUGO-DR-SK12F04G4-00
2	FRAME	STEEL STRIP	1	Ni PLATED	MODEL: SK12F04G4			SCALE: 3:1	DWN. 王骏松 2012-8-14
1	KNOB	POM	1	BLACK	东莞市欧高电子有限公司 DONGGUAN AUGO ELECTRONIC CO.,LTD.			CHK'D	
								APPD.	