

Microcontorl SWITCH

PRODUCT SPECIFICATION 产品规格书

文件编号	FILE NO.	MX3-E	文件版次	EDITION	A. 0
产品编码	PART NO.	MX3-E			
产品描述	Product Name	Micro Switch			

1	General Characteristics 一般特性:				
1.1	Application: This specification is applied to the micro switch (MX3) for general applications. 适用范围: 该承认书指微动开关 (MX3) 的一般使用范围。				
1.2	Operating Temperature Range: -40°C to +85°C 使用温度范围: -40°C to +85°C Preservative Temperature Range: -40°C to +85°C 保存温度范围: -40°C to +85°C				
1.3	Operating Relative Humidity: ≤85%RH 相对湿度: ≤85%RH				
1.4	Test Conditions: Unless otherwise specified, the atmospheric conditions for making measurements and tests are as follows: 实验条件: 若没有特别说明, 则试验大气条件如下: Ambient Temperature: 5~35°C 环境温度: 5~35°C Relative Humidity: 45~85% 相对湿度: 45~85% Air Pressure: 86~106Kpa (860~1060mbar) 大气压力: 86~106Kpa (860~1060mbar)				

2.	Appearance, Structure and Dimensions 外观, 结构及尺寸:				
2.1	Appearance: The switch shall have good finishing, and no rust, crack or plating defects. 外观: 产品外观良好, 无锈蚀、裂纹和镀层缺陷。				
2.2	Structure & Dimensions: Refer to individual product drawing. 结构及尺寸: 参见产品图纸				
2.3	Markings: Refer to individual product drawing. 标识: 参见产品图纸。				

3.	Ratings 额定负荷	CERTIFICATION	RATING	LIFE CYCLES	FILE NO.
			0.1A 125/250VAC; 3A 12VDC 0.1A 48VDC u 40T85	100,000	

4. Electrical Characteristics 电气特性

No.	Item 项目	Criteria 标准	Test Method 实验方法
4.1	Contact Resistance 接触电阻	500mΩ max. 500mΩ max.	Measured by a voltage drop method at 1A Max, 5VDC. Any equipment with error not more than 5% can be used. Resistance after test is the average of 5 successive measurements. (To measure after operated 5 to 10 times) 以1A, 5V直流电, 采用电压降法测量。也可用误差不超过5%的仪表进行测量, 实验后的电阻取5次测量的平均值。(按动5-10次后测量)

Microcontorl SWITCH

PRODUCT SPECIFICATION 产品规格书

文件编号	FILE NO.	MX3-E	文件版次	EDITION	A. 0
产品编码	PART NO.	MX3-E			
产品描述	Product Name	Micro Switch			
4.2	Insulation Resistance 绝缘电阻	100 MΩ min. 100 MΩ min.	100VDC voltage is applied between each pair of terminals and between the terminal and the metal frame for 60±5S. 在相互绝缘的所有端子之间及各接线端子与外露的非载流金属零件之间加载100V直流电，持续时间60±5S。		
4.3	Dielectric Voltage 抗电强度	No dielectric breakdown shall occur. 无击穿现象发生。	1000VAC (50~60Hz, cut - off current 10mA) is applied between non-connected terminals and 1500VAC between terminals and the metal frame for 60±5S. 在相互绝缘的所有接线端子之间1000V（50-60Hz）交流电，各接线端子与外壳或非载流金属零件之间加载1500V（50-60Hz）交流电，持续时间60±5S。		
5. Mechanical Characteristics 机械特性					
No.	Item 项目	Criteria 标准	Test Method 实验方法		
5.1	Operating Force 操作力	See product drawing 参见产品图纸	Apply a tension load on the midpoint of the actuator (or 1mm to the tip of the shaft) to supply a pressure vertically from its free position to operating position. 在操作元件中间(或在离操作元件末端1mm处)沿操作方向均匀施加静载荷，使操作元件转换到动作位置。		
5.2	Releasing Force 回复力	See product drawing 参见产品图纸	A static load shall be reduced to the tip of actuator in operating direction to change component from operating position to release position. 在操作元件末端沿操作方向均匀减少静载荷，使操作元件从动作位置转换到释放位置。		
5.3	Free position 自由位置	See product drawing 参见产品图纸	The position where the actuator lead the Displacements when its out of force or the force is not enough to drive the actuator. 驱动件在不承受操作力以及不足以引起位移时所处的位置		
5.4	Operating Position 操作位置	See product drawing 参见产品图纸	The distance from the end of operating component to the center of mount hole when switch is being transformed 开关发生转换时，操作元件末端到开关安装孔中心的距离		
5.5	Pre Travels 行程	See product drawing 参见产品图纸	The distance vertically through, which the midpoint of the actuator (or tip of the shaft) trip move from its free position to operating position. 从自由位置到动作位置的距离。		
5.6	Differential Travel 差程	See product drawing 参见产品图纸	The distance from operating position to release position 从动作位置到释放位置的距离。		

Microcontorl SWITCH

PRODUCT SPECIFICATION 产品规格书

文件编号	FILE NO.	MX3-E	文件版次	EDITION	A. 0
产品编码	PART NO.	MX3-E			
产品描述	Product Name	Micro Switch			
5.7	Over travel 超行程	See product drawing 参见产品图纸	The displacements of actuator form operation to total travel position. 驱动件从动作位置到全行程位置间的位移 .		
6. Durability characteristics					
No.	Item 项目	Criteria 标准	Test Method 实验方法		
6.1	Mechanical Life	After test, Contact resistance: 500mΩ max. Insulation resistance:50MΩ min. The electrical performance requirements specified in item 4.3 shall be satisfied. The switch shall be free from abnormalities in appearance construction. Operating force: within ±30% initialization value.	500,000 cycles of operation shall be performed continuously at a rate of 60 cycles per minute without load.		
	机械寿命	实验后: 电气性能应符合第4.3条的要求。 开关外观及结构应无损坏。 操作力变化为初始值的 ±30%。	在不带负荷的条件下, 速度为60次/分, 在寿命试验设备上连续转换500,000次。		
6.2	Operating Life with Load	After test, Insulation resistance:10MΩ min. The electrical performance requirements specified in item 4.3 shall be satisfied. The switch shall be free from abnormalities in appearance construction. Operating force: within ±30% initialization value.	CQC(GB15092.1)/ENEC (EN61058-1) : 100,000 cycles of oper a shall be performed continuously at a rate of 30-60 cycles per minute with load as follow: Refer to individual product drawing (Resistive Load)		
	负荷寿命	实验后: 绝缘电阻: 10MΩ min. 电气性能应符合第4.3条的要求。 开关外观及结构应无损坏。 操作力变化为初始值的 ±30%。	CQC(GB15092.1)/ENEC(EN61058-1): 在产品图纸标示负荷的下, 在寿命试验设备上连续转换100,000次, 30-60次/分。		

Microcontorl SWITCH

PRODUCT SPECIFICATION 产品规格书

文件编号	FILE NO.	MX3-E	文件版次	EDITION	A. 0
产品编码	PART NO.	MX3-E			
产品描述	Product Name	Micro Switch			

7. Weather Proof Characteristics 耐候性能:

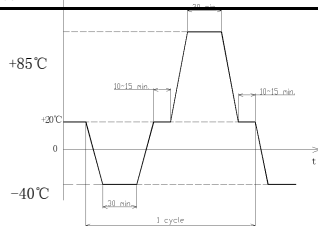
7.1	Cold Proof		After testing at $-40 \pm 2^{\circ} \text{C}$ for 96 hours, the switch shall be allowed to stand under normal temperature and humidity conditions for 1 hour, and measurement shall be made within 1 hour after that. Water drops shall be eliminated.
	低温		试件在 $-40 \pm 2^{\circ}\text{C}$ 的温控箱内保持96小时, 然后在正常温度和湿度下恢复1小时, 并在此后1小时内对试品进行测量, 水滴应消失。
7.2	Hot Proof	After test, Contact resistance: $500\text{m}\Omega$ Max. Insulation resistance: $50\text{M}\Omega$ Min.	After testing at $85 \pm 2^{\circ} \text{C}$ for 96 hours, the switch shall be allowed to stand under normal temperature and humidity conditions for 1 hour, and measurement shall be made within 1 hour after that.
	高温		试件在 $85 \pm 2^{\circ}\text{C}$ 的温控箱内保持96小时, 然后在正常温度和湿度下恢复1小时, 并在此后1小时内对试品进行测量, 水滴应消失。
7.3	Moisture Resistance	The Electrical performance requirements specified in item 4.3 shall be satisfied. The switch shall be free from abnormalities in appearance & construction.	After testing at $40 \pm 2^{\circ} \text{C}$, 90~95% RH for 96 hours, the switch shall be allowed to stand under normal temperature and humidity conditions for 1 hour, and measurement shall be made within 1 hour after that. Water drops shall be eliminated.
	恒定湿热	实验后: 接触电阻: $500\text{m}\Omega$ Max. 绝缘电阻: $50\text{M}\Omega$ Min. 电气性能应符合第4.3条的要求。 开关外观及结构应无损坏。	试件在 $40 \pm 2^{\circ}\text{C}$, 90-95%RH的温控箱内保持96小时, 然后在正常温度和湿度下恢复1小时, 并在此后1小时内对试品进行测量, 水滴应消失。
7.4	Temperature Cycling		After 4 cycles of following conditions, the switch can stay under normal temperature and humidity conditions for 2 hours, and measurement shall be made within 1 hour after that. Water drops shall be eliminated.
	温度转换		试件按下述实验条件试验 4个循环, 然后在正常温度和湿度下恢复 2小时, 并在此后 1小时内对试品进行测量, 水滴应消失。 

Microcontorl SWITCH

PRODUCT SPECIFICATION 产品规格书

文件编号 FILE NO.	MX3-E	文件版次 EDITION	A. 0
产品编码 PART NO.	MX3-E		
产品描述 Product Name	Micro Switch		

8. Material List 材料清单

No. 序号	零部件名称 Parts Name	数量 Quantity	材料, 规格 Material and Specifications	防火等级 Prevent fire grade	备注 Remarks
1	胶盖 Cover	1	PA		
2	胶壳 Base	1	PA		
3	按钮 Actuating button	1	POM		
4	密封圈 Sealed Circle	1	Silicone Rubber		
5	COM端子 COM Terminal	1	Cu Alloy		Ag PLATED
6	弹簧 Spring	1	Cu Alloy		
7	动片 Moving Blade	1	Cu Alloy		Ag PLATED
8	动片触点 MB Contact	2	Ag Alloy		
9	NO端子 NO Terminal	1	Cu Alloy		Ag PLATED
10	NO 端子触点 NO Contact	1	Ag Alloy		
11	NC 端子 NC Terminal	1	Cu Alloy		Ag PLATED
12	NC 端子触点 NC Contact	1	Ag Alloy		
13	密封胶水 Sealed Glue	/	Epoxy Resin		

9. Operating data diagram 操作参数示意图

OF :Operating Force OP : Operating Position TT :Total Travel
 RF :Release Force TTP: Total Travel Position TF :Total travel Force
 RP :Release Position FP : Free Position PT :Pre Travel
 OT :Over Travel DT : Differential Travel

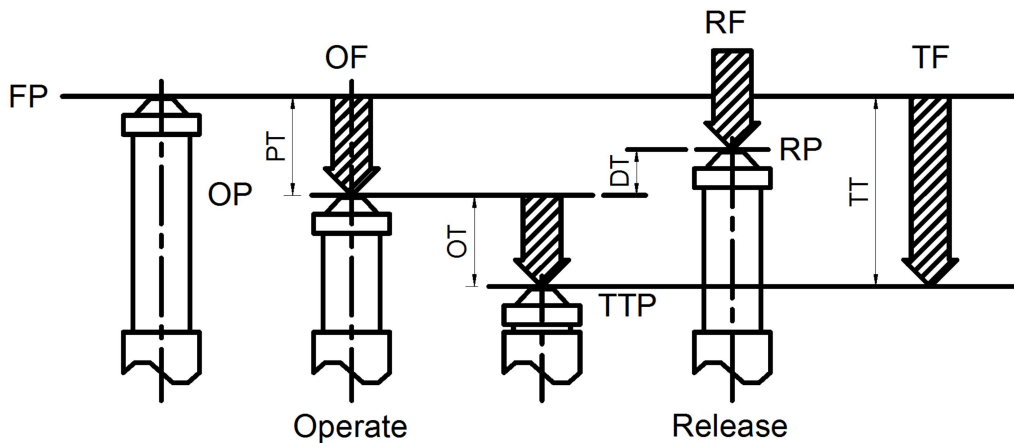

REV	MARK	DESCRIPTION	DRAFTED. BY	DATE

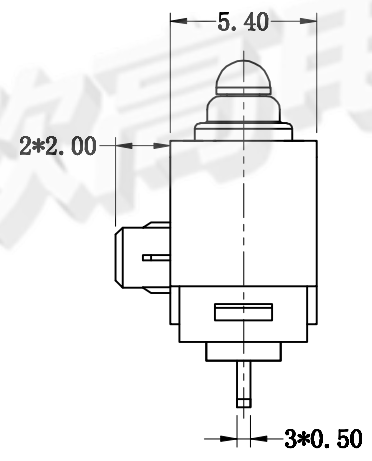
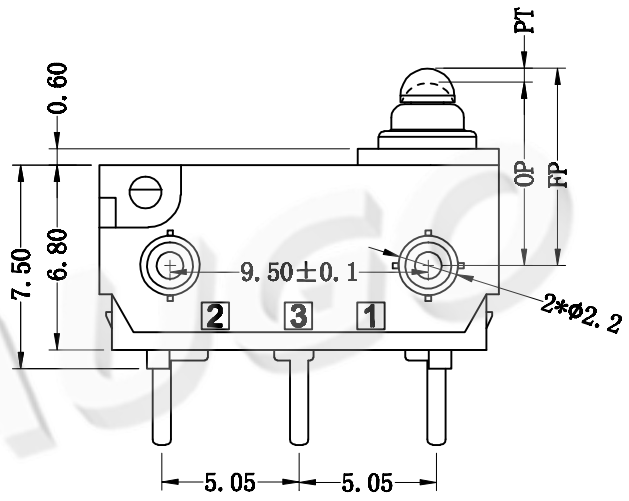
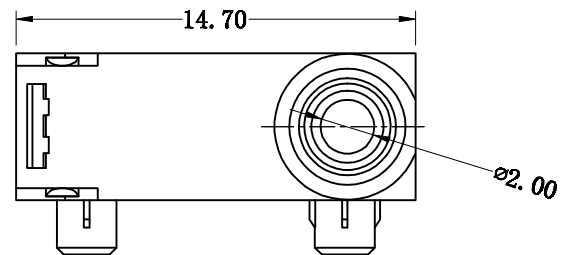

CHARACTERISTICS	
OPERATING FORCE (OF):	130gf Max.
RELEASE FORCE (RF):	20gf Min.
OPERATING POSITION:	6.75 ± 0.20 mm.
PRE TRAVEL:	0.80mm Max.
DIFFERENTIAL TRAVEL:	0.20mm Max.
FREE POSITION:	7.35mm Max.

ELECTRICAL DATA	
RATING	OPERATING LIFE
3A 12VDC	100,000 CYCLES
0.1A 48VDC 125/250VAC	100,000 CYCLES

MECHANICAL LIFE	500,000 CYCLES
GAP TYPE	MICRO
OPERATING TEMP	-20°C ~ +85°C
WATERGROOF	IP67

OUTLINE DRAWING			
TITLE			
MODEL	MX3-E		
PART NO.			
DRAFTED BY	BING WANG	DATE	2020-6-13
CHECKED BY	GUO FU LUO	DATE	2020-6-13
APPROVED BY	MATH	DATE	2020-6-13

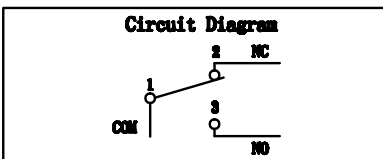

TOLERANCE UNLESS OTHERWISE SPECIFIED							
	1~3	3~10	10~30	30~100	100~200	ANGLE	
±0.2	±0.3	±0.4	±0.6	±1.0	±1.5	±3.0°	

SCALE	
UNIT	MM
VERSION	REV A1

AUGO ELECTRONICS

1 2 3 4 5 6 7 8 9 10